

Integrated Professional Cleaning



IPC Gansow

CT15 - CT30 - CT15 ECS - CT45

Lavamatic 360 - Lavamatic 460

Lavamatic 15 - Lavamatic 30

Lavamatic 45



MANUALE ISTRUZIONI PER L'USO /
OPERATOR'S MANUAL / MANUEL D'INSTRUCTIONS /
BEDIENUNGSANLEITUNG /
MANUAL DE INSTRUCCIONES / BRUKERHÅNDBOK /
GEBRUIKERSHANDLEIDING / MANUAL DE UTILIZAÇÃO /
INSTRUKTIONSBOK / МАШИНА ДЛЯ МОЙКИ И СУШКИ ПОЛОВ
/ KULLANIM KILAVUZU / 自动洗地车操作说明书

Consultare attentamente questo manuale prima di procedere a qualsiasi intervento sulla macchina
Read this manual carefully before carrying out any work on the machine
Lire attentivement ce manuel avant toute intervention sur la machine
Vorliegendes Handbuch vor jedem Eingriff an der Maschine aufmerksam durchlesen
Consulte detenidamente este manual antes de llevar a cabo cualquier trabajo en la máquina
Konsulter denne håndboken nøye før du går i gang med noen som helst type inngrep på maskinen
Raadpleeg deze handleiding aandachtig alvorens met enige werkzaamheid aan de machine te beginnen
Consulte atentamente este manual antes de efectuar qualquer intervenção na máquina
Läs noggrant igenom denna handbok innan du utför något som helst ingrepp på maskinen
Внимательно ознакомьтесь с данной инструкцией до проведения любой работы с машиной
Makine ile herhangi bir işlem yapmadan önce bu kılavuzu dikkatle okuyun
开始使用机器之前，请务必仔细阅读此使用说明书

ENGLISH
**(Translation of original
instructions)**



CT15 TECHNICAL SPECIFICATIONS	4
CT30 TECHNICAL SPECIFICATIONS	6
CT45 TECHNICAL SPECIFICATIONS	8
MACHINE DIMENSIONS	10
SAFETY SYMBOLS.....	12
Battery charger	13
Figure.....	14
GENERAL INFORMATION	20
Scope of the manual	20
Identifying the machine	20
Documentation provided with the machine	20
TECHNICAL INFORMATION.....	21
General description	21
Legend	21
Danger zones.....	21
Accessories.....	21
SAFETY INFORMATION	21
Safety regulations	21
HANDLING AND INSTALLATION	23
Lifting and transporting the packaged machine	23
Checks on delivery.....	23
Unpacking	23
Power supply batteries (battery models).....	24
Batteries: preparation.....	24
Batteries: installation and connection.....	24
Batteries: removal	25
Battery charger (battery models).....	25
Choosing a battery charger (machines without ON-BOARD battery charger)	25
Preparing the battery charger	25
Lifting and transporting the machine.....	25
PRACTICAL GUIDE FOR THE OPERATOR.....	25
Controls - Description.....	25
Mounting and adjusting the squeegee	26
To move the machine, proceed as follows:	27
Mounting and changing the brush/drive disks.....	27
Detergents - Instructions.....	27
Preparing the machine for work	28
Working	28
At the end of work:	29
Some useful tips to get the most from your scrubber drier	29
Carpet cleaner accessory	29
Combi accessory.....	29
Draining the dirty water	30
Draining the clean water	30
PERIODS OF INACTIVITY	30
BATTERY MAINTENANCE AND CHARGING	30
MAINTENANCE INSTRUCTIONS	31
Maintenance - General rules.....	31
Routine maintenance	31
Squeegee blades: replacing	31
Fuses: replacement (battery models) (Fig. L)	32
Fuses: replacement (cable models) (fig. M).....	32
Routine maintenance	32
Six monthly operations.....	32
TROUBLESHOOTING	33
How to resolve possible problems	33

CT15 TECHNICAL SPECIFICATIONS

		CT15 B	CT15 ECS	CT15 C	CT15 B R	CT15 C R
Cleaning width	mm	355			360	360
Squeegee width	mm	450			430	430
Cleaning capacity per hour	m ² /h	1300			1300	1300
Number of brushes	n°	1				
Brush diameter	mm	355			100	
Maximum brush pressure	g/cm ²	/				
Brush rotation speed	g/1°	140	600	140	1120	820
Brush motor power	W	200	450	250	250	370
Drive motor power	W	/				
Maximum speed	Km/h	/				
Suction motor power	W	550	200	400	550	400
Solution tank	L	15				
Dirty water tank	L	16,5				
Rear wheel diameter	mm	250				
Maximum slope	%	/				
Gross weight	Kg	95	95	52,5	74,5	69,5
Transported weight	Kg	36	36	15	36	15
Number of batteries	n°	2	2	/	2	/
Battery voltage	V	12	12	/	12	/
Individual battery capacity	Ah (5h)	29		/	29	/
Power system voltage	V	24	24	110-240	24	110-240
Machine dimensions	mm	X=790 Z=1180 Z1=690 Y=468			X=750 Z=1180 Z1=690 Y=435	X=750 Z=1180 Z1=690 Y=435
Battery compartment dimensions (length, width, height)	mm	205x265x205		/	205x265x205	/
Packed size (length, width, height)	mm	800x450x640			900x610x960	
Sound pressure	LpA (dB)	68	68	70	72	74
Measurement uncertainty	K (dB)	/	/	/	/	/
Vibration level (hand)	HAV m/sec ²	1	1	1,1	1,6	1,6
Measurement uncertainty, k	m/sec ²	0,5	0,5	0,5	0,8	0,8



Vibration level (body)	HBV m/sec ²	/	/	/	/	/
Measurement uncertainty, k	m/sec ²	/	/	/	/	/
Maximum water and detergent temperature	°C	4 - 55				
Battery charger	V	100 - 240		/	100 - 240	/
	Hz	50 - 60		/	50 - 60	/
Power supply frequency	Hz	/	/	50 - 60	/	50 - 60
Power supply	V	24	24	115 110 - 240	24	115 110 - 240
Rated power	W	750	650	650	800	770
Rated current	A	31	27	5,6 2,8	33	6,7 3,3

Data subject to variation without warning.



CT30 TECHNICAL SPECIFICATIONS

		CT30 B	CT30 ECS	CT30 C
Cleaning width	mm	455		
Squeegee width	mm	545		
Cleaning capacity per hour	m ² /h	1670		
Number of brushes	n°	1		
Brush diameter	mm	455		
Maximum brush pressure	g/cm ²	/		
Brush rotation speed	g/1°	140	600	140
Brush motor power	W	350	350	400
Drive motor power	W	/		
Maximum speed	Km/h	/		
Suction motor power	W	550	200	400
Solution tank	L	28		
Dirty water tank	L	30		
Rear wheel diameter	mm	250		
Maximum slope	%	/		
Gross weight	Kg	126	126	81
Transported weight	Kg	76	76	28
Number of batteries	n°	2		
Battery voltage	V	12		
Individual battery capacity	Ah (5h)	74		/
Power system voltage	V	24		
Machine dimensions	mm	X=850 Z=1220 Z1=745 Y=568		
Battery compartment dimensions (length, width, height)	mm	240x330x220		/
Packed size (length, width, height)	mm	900x610x960		
Sound pressure	LpA (dB)	69	/	79,6
Measurement uncertainty	K (dB)	/	/	/
Vibration level (hand)	HAV m/sec ²	1	/	1,1
Measurement uncertainty, k	m/sec ²	0,5	/	0,5

Vibration level (body)	HBV m/sec ²	/	/	/
Measurement uncertainty, k	m/sec ²	/	/	/
Maximum water and detergent temperature	°C	4 - 55		
Battery charger	V	100 - 240		/
	Hz	50 - 60		/
Power supply frequency	Hz	/	/	50 - 60
Power supply	V	24	24	115 110 - 240
Rated power	W	900	/	800
Rated current	A	37,5	/	7 3,7

Data subject to variation without warning.



CT45 TECHNICAL SPECIFICATIONS

		CT45 B	CT45 BT	CT45 C
Cleaning width	mm	500		
Squeegee width	mm	730		
Cleaning capacity per hour	m ² /h	1750		
Number of brushes	n°	1		
Brush diameter	mm	500		
Maximum brush pressure	g/cm ²	/		
Brush rotation speed	g/1°	160		140
Brush motor power	W	400		450
Drive motor power	W	180		
Maximum speed	Km/h	3,5		
Suction motor power	W	550		400
Solution tank	L	40		
Dirty water tank	L	45		
Rear wheel diameter	mm	250		
Maximum slope	%	/		
Gross weight	Kg	140	145	105
Transported weight	Kg	88	88	40
Number of batteries	n°	2		
Battery voltage	V	12		
Individual battery capacity	Ah (5h)	74		/
Power system voltage	V	24		
Machine dimensions	mm	X=980 Z=1290 Z1=806 Y=715		
Battery compartment dimensions (length, width, height)	mm	265x335x255		/
Packed size (length, width, height)	mm			
Sound pressure	LpA (dB)	69	/	80
Measurement uncertainty	K (dB)	/	/	/
Vibration level (hand)	HAV m/sec ²	1	/	1
Measurement uncertainty, k	m/sec ²	0,5	/	0,5

Vibration level (body)	HBV m/sec ²	/	/	/
Measurement uncertainty, k	m/sec ²	/	/	/
Maximum water and detergent temperature	°C	4 - 55		
Battery charger	V	100 - 240		/
	Hz	50 - 60		/
Power supply frequency	Hz	/	/	50 - 60
Power supply	V	24	24	115 110 - 240
Rated power	W	950	1130	850
Rated current	A	39,5	47	7,4 3,7

Data subject to variation without warning.



MACHINE DIMENSIONS

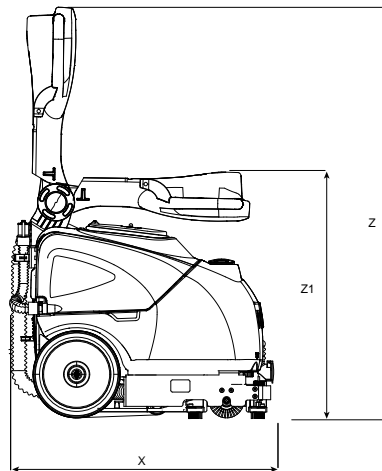
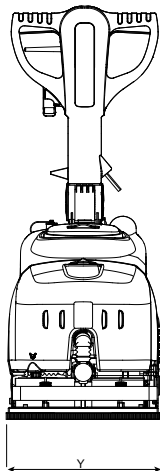
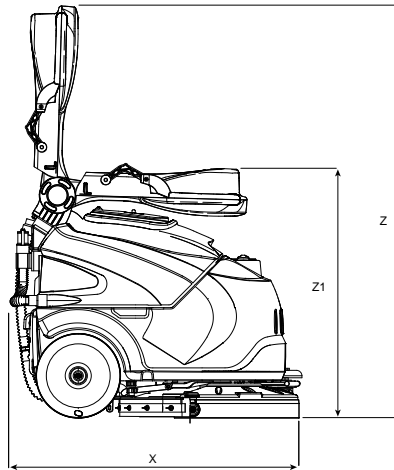
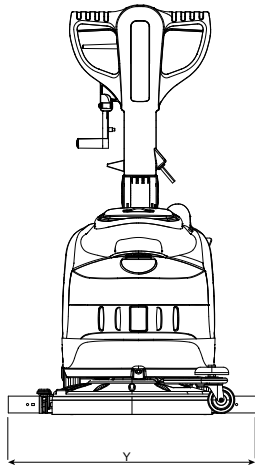



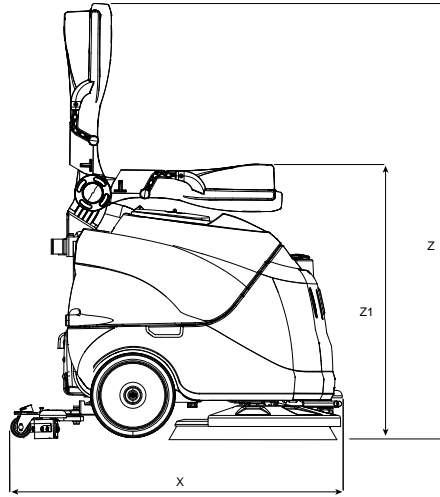
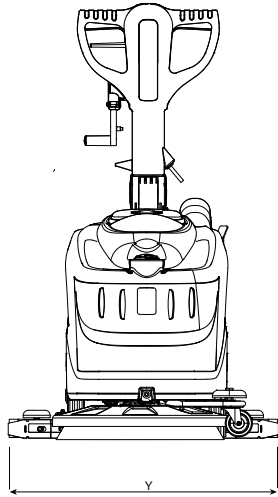





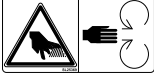

X-Y-Z: See "TECHNICAL SPECIFICATIONS" table

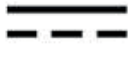

X-Y-Z: See "TECHNICAL SPECIFICATIONS" table

SAFETY SYMBOLS

	WARNING! RISK OF CUTTING
	WARNING! RISK OF CRUSHING LIMBS
	WARNING! RISK OF ABRASION
	WARNING! RISK OF ENTANGLEMENT
	WARNING! RISK OF ACID BURNS
	WARNING! RISK OF BURNS
	MAXIMUM SLOPE
	OPERATOR'S MANUAL, OPERATING INSTRUCTIONS
	READ THE OPERATOR'S MANUAL
	DIRECT CURRENT SYMBOL
	INSULATION CLASS, THIS CLASSIFICATION ONLY APPLIES TO MACHINES POWERED BY BATTERIES.

BATTERY CHARGER

Dipswitches are located behind the round black cap located on the front side of the charger and next to the green led you will find 2 sets of dipswitches (SW1 and SW2).

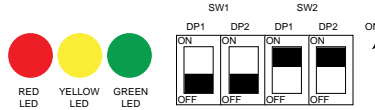

CT15			
SW1		SW2	
DP1	DP2	DP1	DP2
Charging current	Charging Termination	Curve	TCL Function
ON: half charging current (2,5A)	ON: stop charge	OFF: IUUO-GEL for generic GEL and AGM batteries	OFF: TCL enabled
OFF: maximum charging current (5A)	OFF: floating charge at 27,6V	ON: IUla-AGM DISCOVER for DISCOVER AGM batteries	ON: TCL disabled
Default Setting	Default Setting	Default Setting	Default Setting

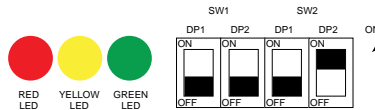

CT30 ECO			
SW1		SW2	
DP1	DP2	DP1	DP2
Charging current	Charging Termination	Curve	TCL Function
ON: half charging current (2,5A)	ON: stop charge	ON: IUla-AGM DISCOVER for DISCOVER AGM batteries	OFF: TCL enabled
OFF: maximum charging current (5A)	OFF: floating charge at 27,6V	OFF: IUUO-GEL for generic GEL and AGM batteries	ON: TCL disabled
Default Setting	Default Setting	Default Setting	Default Setting

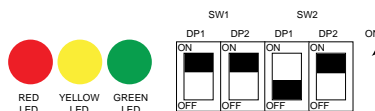

CT30 - CT45							
SW1				SW2			
DP1	DP2	Curve		DP1	V	DP2	
ON	OFF	IUla-ACD for Wet batteries		OFF	24	ON	TCL disabled Default Setting
OFF	OFF	IUla-GEL for GEL batteries of Exide-Sonnenschein and Haze		ON	12	OFF	TCL enabled
OFF	ON	IUUO-GEL for GEL and AGM batteries of other manufacturers					
ON	ON	IUla-AGM for Discover AGM batteries					
		Default Setting					



FIGURE

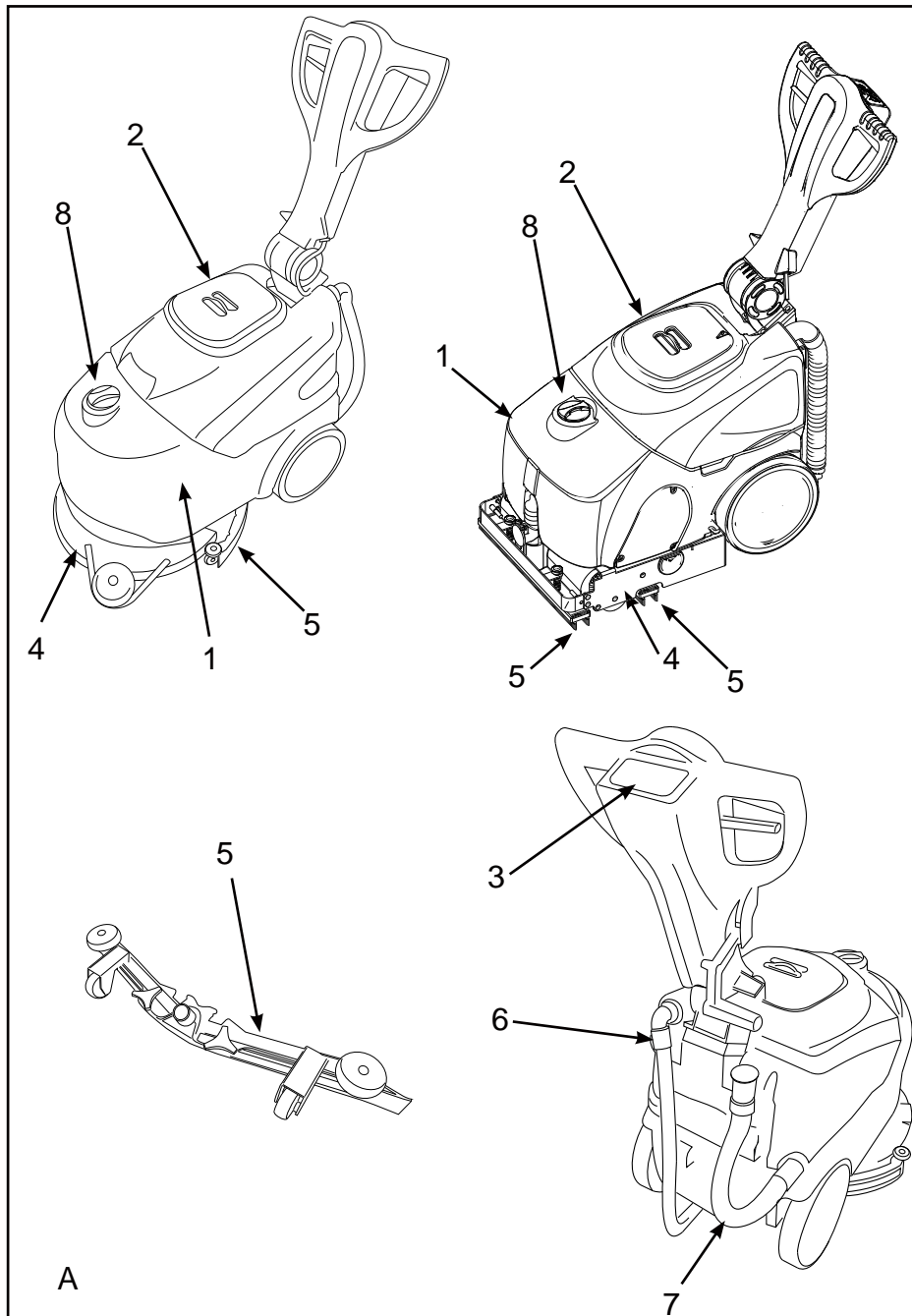

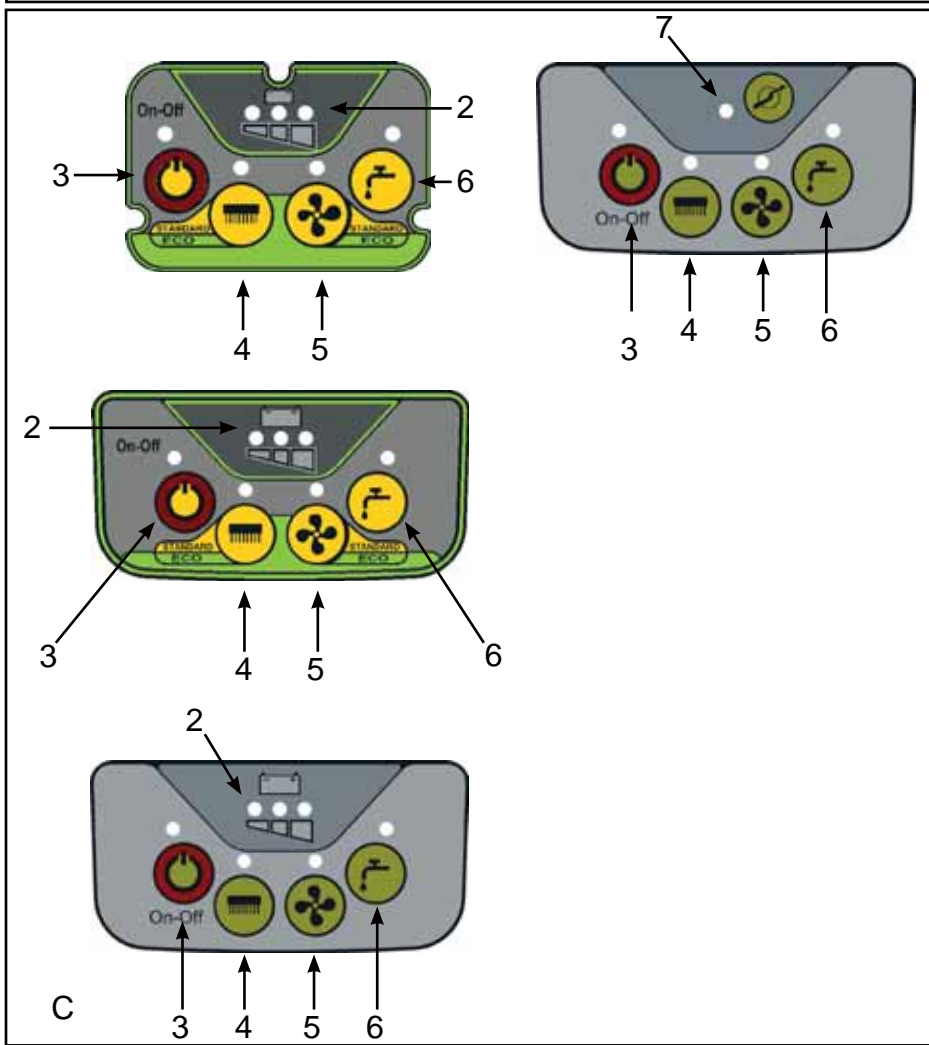
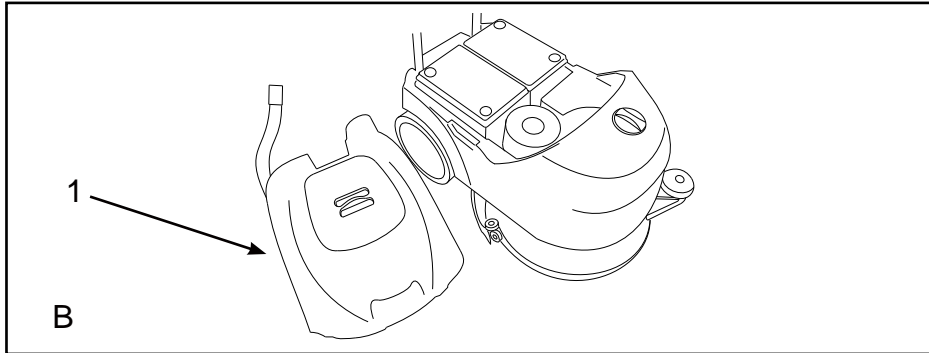

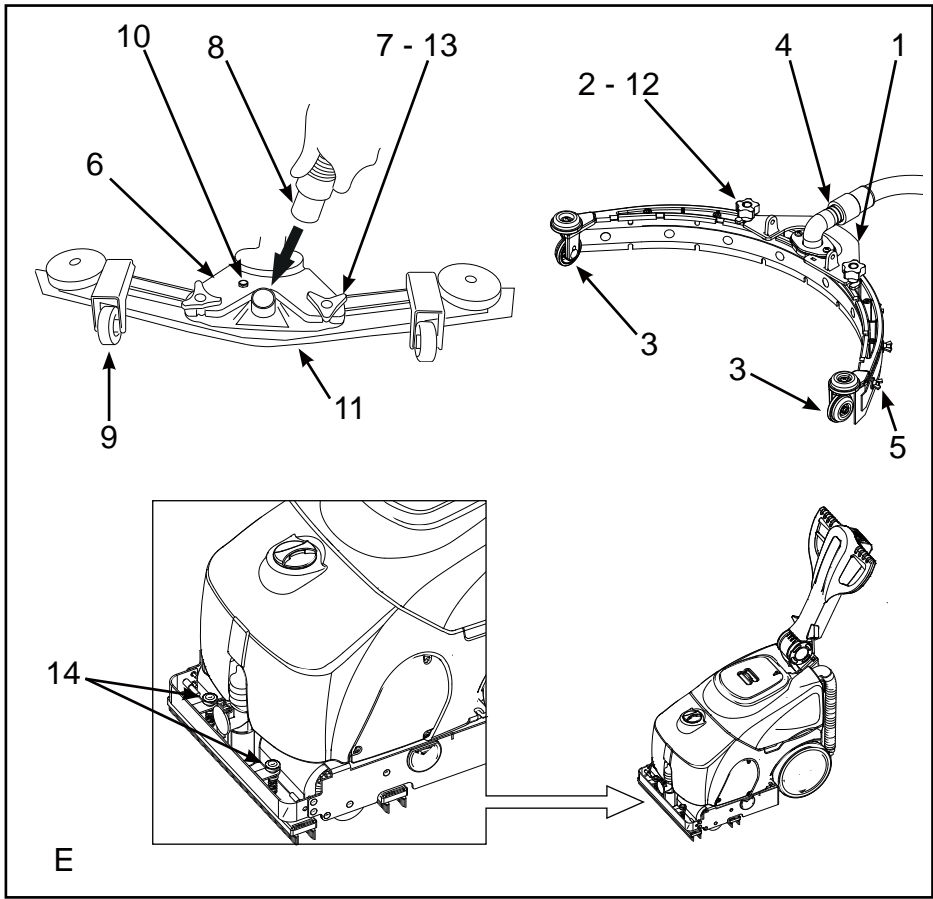
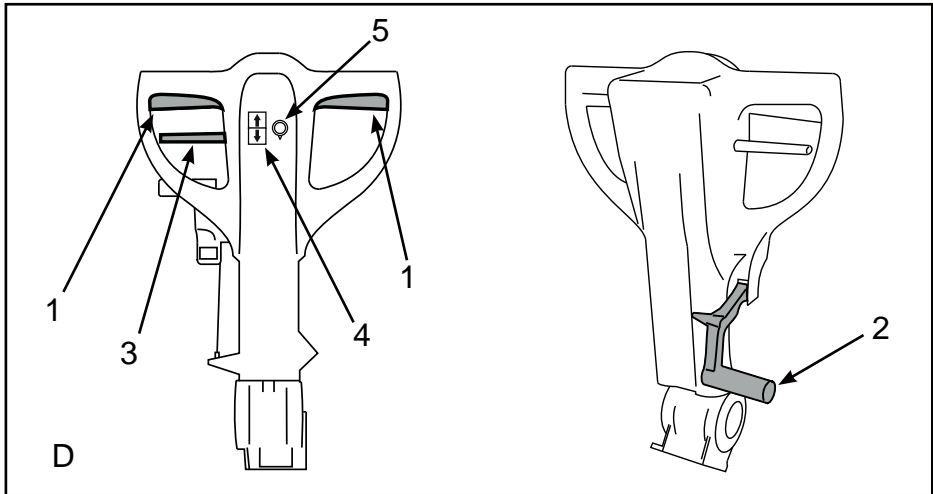

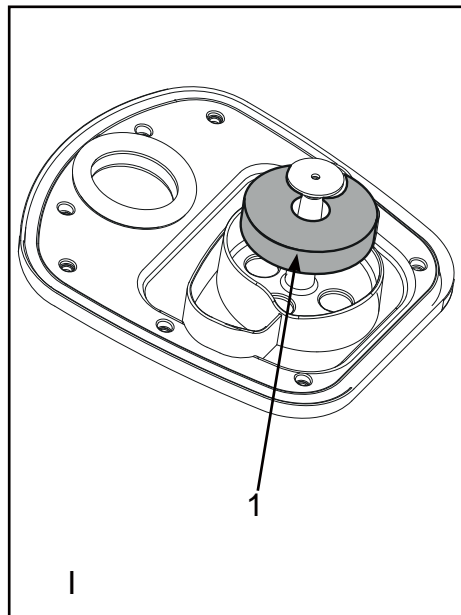
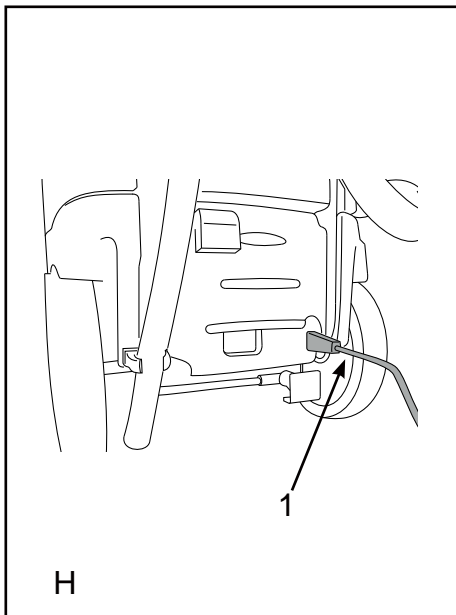
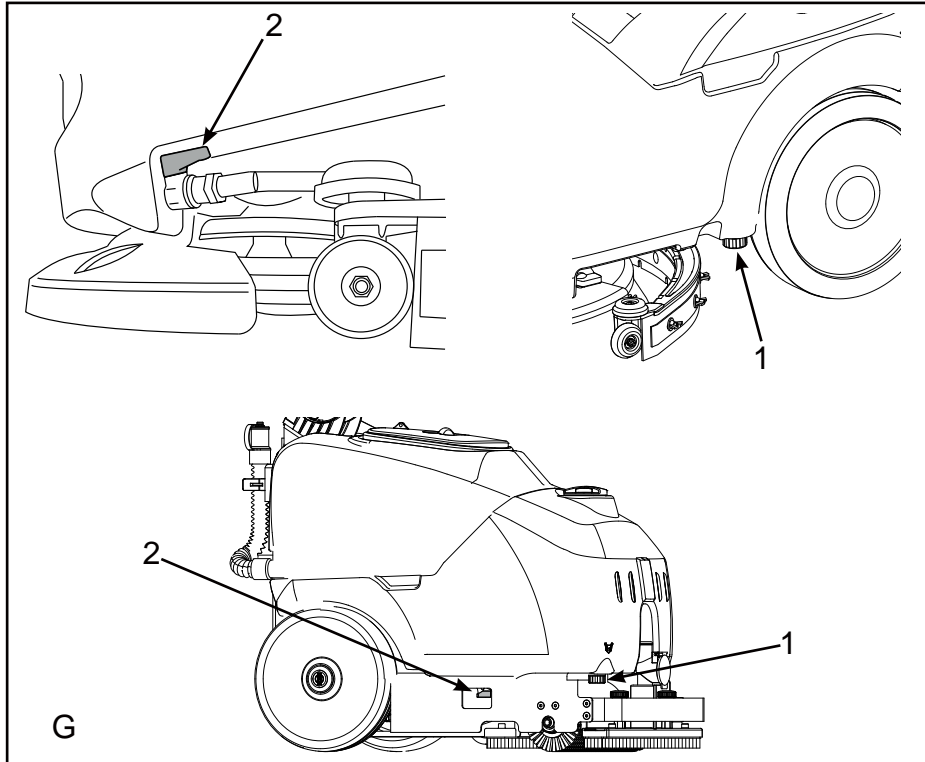

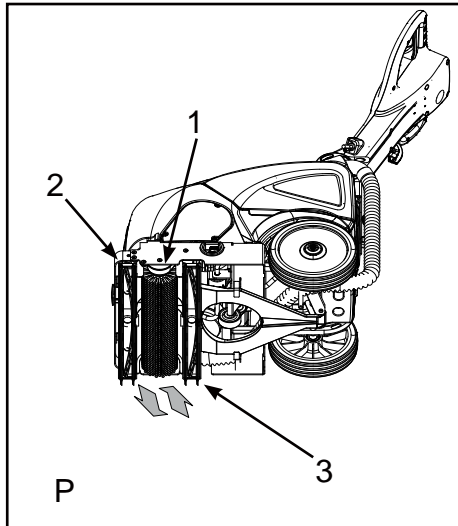
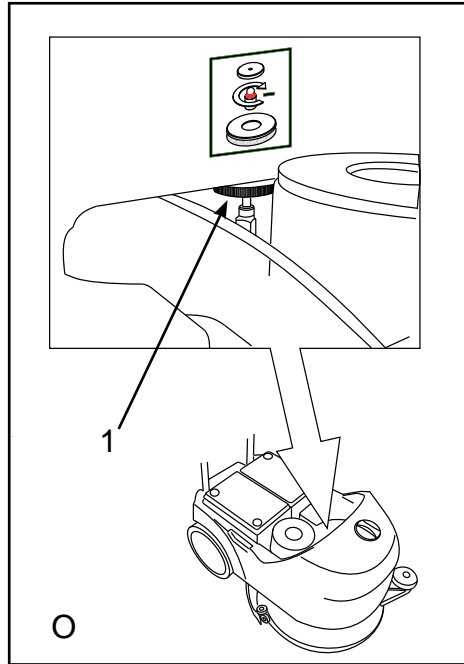
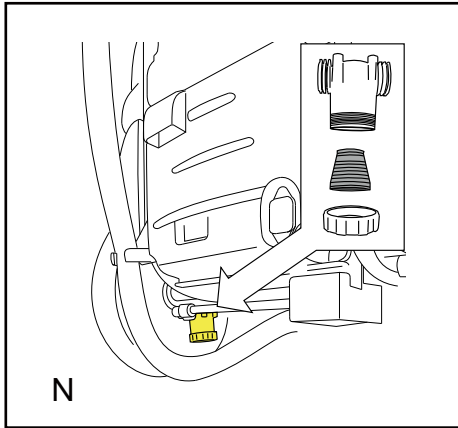
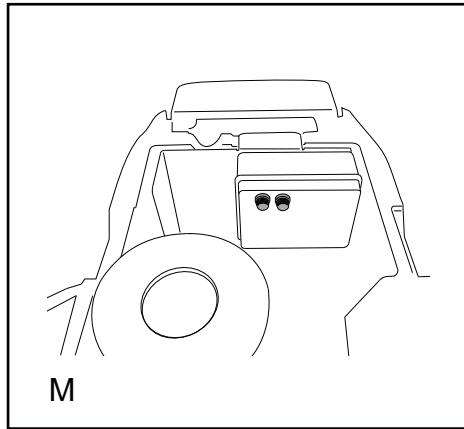
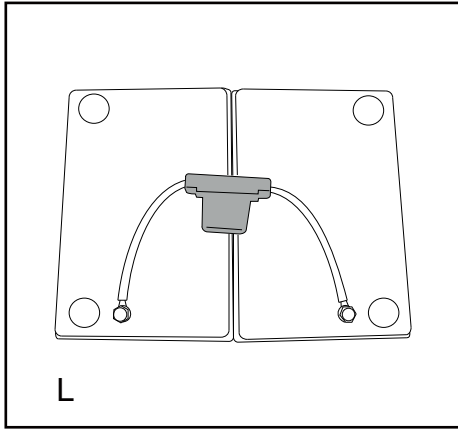

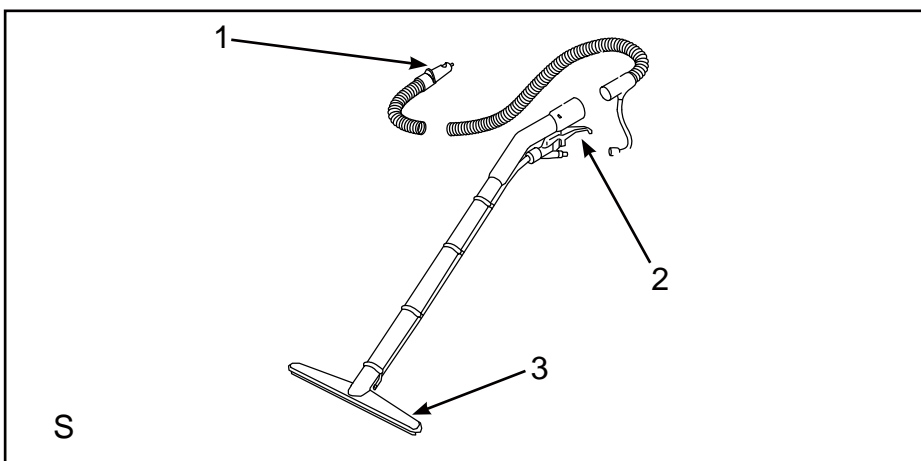
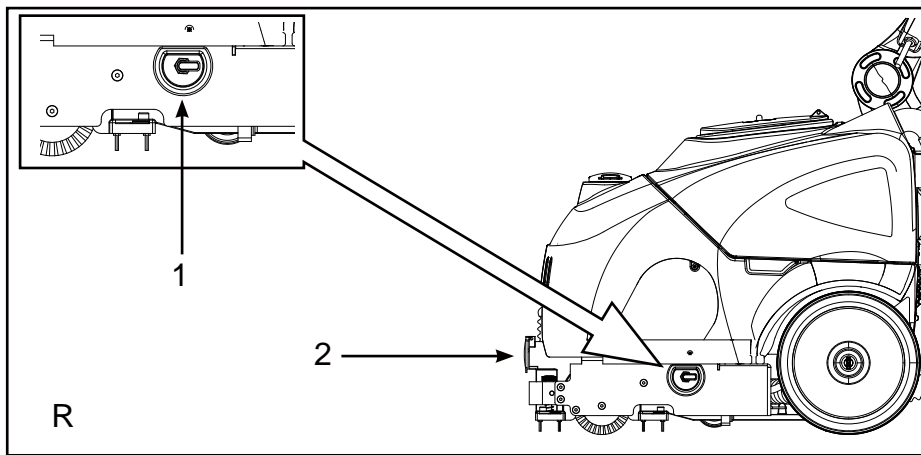
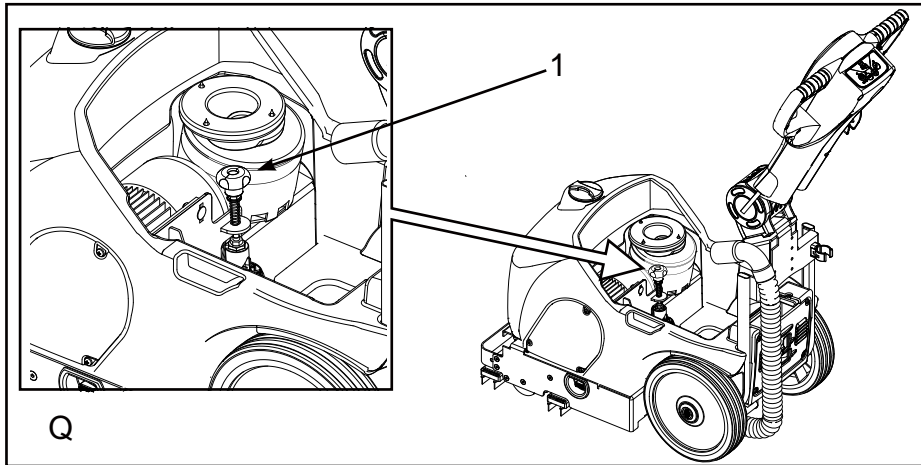

GENERAL INFORMATION

INFORMATION

Read this manual carefully before carrying out any work on the machine

Scope of the manual

This manual has been written by the Manufacturer and is an integral part of the **machine**¹. It defines the purpose for which the machine has been designed and constructed and contains all the information required by **operators**².

In addition to this manual, which contains information for operators, other publications are available providing specific information for **maintenance personnel**³.

The terms "right" and "left", "clockwise" and "anti-clockwise" refer to the forward movement of the machine.

Constant compliance with the instructions provided in this manual guarantees the safety of the operator and the machine, ensures low running costs and high quality results and extends the working life of the machine. Failure to follow these instructions may lead to injury to the operator or damage to the machine, floor and environment.

Consult the table of contents at the beginning of the manual to find the section you need rapidly.

Parts of the text requiring special attention are printed in bold and preceded by the symbols illustrated and described here.

DANGER

Indicates the need for attention in order to avoid a series of consequences which could cause death or damage to the health of the operator.

IMPORTANT

Indicates the need for attention in order to avoid a series of consequences which could cause damage to the machine or work environment or financial loss.

INFORMATION

Particularly important instructions.

In line with the company's policy of constant product development and updating, the Manufacturer reserves the right to make modifications without warning.

Although your machine may differ appreciably from the illustrations in this document, safety and the information contained in this manual are guaranteed.

Identifying the machine

The rating plate provides the following information:

- ▶ model;
- ▶ power supply;
- ▶ total nominal power;
- ▶ serial number;
- ▶ year of fabrication;
- ▶ dry weight;
- ▶ maximum slope;
- ▶ barcode with serial number;
- ▶ manufacturer's identification.



Documentation provided with the machine

- ▶ User manual;
- ▶ guarantee certificate;
- ▶ EC certificate of conformity.

¹ The definition "machine" replaces the trade name covered by this manual.

² Persons responsible for using the machine without performing any operations requiring precise technical skills.

³ Persons with experience, technical training and a knowledge of legislation and standards, able to perform all the necessary operations and to recognise and avoid possible risks in handling, installation, use and maintenance of this machine.

TECHNICAL INFORMATION

General description

This machine is a scrubber drier for sweeping, washing and drying flat, horizontal, smooth or moderately rough, even and obstacle free floors in civil and industrial premises. It is available in both battery and cable versions to meet all running time and weight requirements.

The scrubber drier spreads a solution of water and detergent in the correct concentration on the floor and then scrubs it to remove the dirt. By carefully choosing the detergent and brushes (or abrasive disks) from the wide range of accessories available, the machine can be adapted to a wide range of combinations of types of floor and dirt. A suction system incorporated in the machine dries the floor after washing by means of the low pressure generated in the dirty water tank by the suction motor. The squeegee connected to the tank collects the dirty water.

Legend

The main parts of the machine are as follows (fig. A):

- ▶ the detergent tank (fig. A, ref. 1): contains and transports the mixture of clean water and detergent;
- ▶ the dirty water tank (fig. A, ref. 2): collects the dirty water picked up from the floor after washing;
- ▶ control panel (fig. A, ref. 3);
- ▶ head assembly (fig. A, ref. 4): the main element is the brush which distributes the detergent solution on the floor and remove the dirt;
- ▶ squeegee assembly (fig. A, ref. 5): wipes and dries the floor by collecting the water.

Danger zones

- ▶ Tank assembly: when using certain detergents, danger of irritation for eyes, skin, mucous membranes and respiratory tract and of asphyxia. Danger represented by the dirt collected from the environment (germs and chemical substances). Danger of crushing between the two tanks when the dirty water tank is replaced on top of the detergent tank.
- ▶ Control panel: danger of short circuit.
- ▶ Bottom of washing head: danger due to brush rotation.
- ▶ Rear wheels: danger of crushing between the wheel and chassis.
- ▶ Battery compartment (in the detergent tank): danger of short circuit between the battery poles and presence of hydrogen during charging.

Accessories

- ▶ Bristle brushes: for washing delicate floors and polishing;
- ▶ Polypropylene brushes: for normal floor washing;
- ▶ Tynex brushes: for removing accumulated stubborn dirt on resistant floors;
- ▶ Drive disks: enable the following disks to be used:
 - ▶ Yellow disks: for washing and polishing marble and similar surfaces;
 - ▶ Green disks: for washing resistant floors;
 - ▶ Black disks: for thorough washing of resistant floors with stubborn dirt.

SAFETY INFORMATION

Safety regulations

INFORMATION

Read the "User Manual" carefully before start-up and use or before performing maintenance or any other work on the machine.

IMPORTANT

Rigorously respect all instructions in the Manual (in particular those relating to danger and important information) and on the safety plates fitted to the machine.

The Manufacturer declines all liability for damage to people or things resulting from failure to observe the instructions.

The appliance must be used exclusively by persons trained in its use and/or who have demonstrated their ability and have been expressly instructed to use the appliance.

The machine must not be used by minors.

The machine must not be used for purposes other than those for which it was expressly designed. Scrupulously respect all safety standards and conditions applicable to the type of building in which the machine is to be operated (eg: pharmaceutical companies, hospitals, chemicals, etc).

Do not use the machine in places with inadequate lighting or explosive atmospheres, on public roads, in the presence of dirt hazardous to health (dust, gas, etc) and in unsuitable environments.

The machine is designed for indoor use only.



The machine is designed for temperatures of between +4°C and +35°C when in use and between +0°C and +50°C when not in use.

The machine is designed to work in a humidity of between 30% and 95%.

Never use or pick up flammable liquids or explosives (e.g. petrol, fuel oil, etc), flammable gases, dry dusts, acids and solvents (e.g. paint solvents, acetone etc) even if diluted. Never pick up flaming or incandescent objects.

Never use the machine on slopes or ramps of more than 2%. In the case of slight slopes, do not use the machine transversally, always manoeuvre with care and do not reverse. When transporting the machine on steeper ramps or slopes, take the utmost care to avoid tipping up and/or uncontrolled acceleration. Tackle ramps and/or steps with the front of the machine raised only.

Never park the machine on a slope.

The machine must never be left unattended with the motor or engine on. Before leaving it, turn the motor or engine off, make sure it cannot move accidentally.

Always pay attention to other people, children in particular, present in the place where you are working.

Children must be supervised to make sure they do not play with the appliance.

The appliance is not intended for use by persons (including children) with reduced physical, sensory or mental capabilities, or lack of experience and knowledge, unless they have been given supervision or instruction concerning use of the appliance by a person responsible for their safety.

Never use the machine to transport people or things or to tow things. Do not tow the machine.

Never rest objects of any weight on the machine for any reason.

Never obstruct ventilation and heat dispersion slits.

Never remove, modify or circumvent safety devices.

Numerous unpleasant experiences have shown that a wide range of personal objects may cause serious accidents. Before beginning work, remove jewellery, watches, ties, etc.

The operator must always use personal protection devices - protective apron or overalls, non-slip waterproof shoes, rubber gloves, protective goggles and ear protectors and mask to protect the respiratory tract.

Keep the hands away from moving parts.

Never use detergents other than those specified. Follow the instructions on the relative safety sheet. We recommend keeping detergents out of reach of children. In the event of contact with the eyes, wash immediately with abundant water. If ingested, consult a doctor immediately.

Make sure the power sockets used for the models with cable or battery charger are connected to a suitable earth system and protected by differential thermal solenoid switches.

Make sure the electrical characteristics of the machine (voltage, frequency, absorbed power) given on the rating plate are the same as those of the mains electricity supply. The machine with cable has a three-wire cable and a three pin earthed plug for use in an appropriate earthed socket. The earth wire is yellow and green. Never connect this wire to anything other than the earth contact of the socket.

It is indispensable to respect the battery manufacturer's instructions and current legislation. The batteries should always be kept clean and dry to avoid surface leakage current. Protect the batteries from impurities such as metal dust.

Never rest tools on the batteries as this could cause short circuit and explosion.

When using battery acid, always follow the relative safety instructions scrupulously.

When using cable models, take care not to crush or pull the power supply cable.

While using the machine, make sure the rotating brush does not come in contact with the power cable (cable powered version).

Check the power cable regularly. If damaged, do not under any circumstances use the machine. Replace it with one of the same type or contact a specialised service centre (cable powered version).

In the presence of particularly strong magnetic fields, assess the possible effect on the control electronics.

Never wash the machine with water jets.

The fluids collected contain detergent, disinfectant, water and organic and inorganic material. They must be disposed off in accordance with current legislation.

In the case of malfunction and/or faulty operation, turn the machine off immediately (disconnecting it from the mains power supply or batteries) and do not tamper. Contact a service centre authorised by the Manufacturer.

All maintenance operations must be performed in an adequately lit place and only after disconnecting the machine from the power supply, in cable models by unplugging the machine from the socket, in battery models by disconnecting the battery connector; in cable models, the operator must be able to verify from any position that the machine remains unplugged from the mains socket while maintenance is being carried out.

In general, in an emergency, power to the machine can be quickly disconnected (battery version) by removing the fuse (fig. L).

All work on the electrical system and all maintenance and repair operations other than those explicitly described in this manual must be performed by specialised personnel expert in the sector only.

If the power cable, plug or terminals require replacing, make sure the electrical connections and cable grip are tightly fastened to guarantee the resistance of the cable if pulled. Only original accessories and spare parts supplied by the Manufacturer may be used in order to guarantee safe problem-free operation of the machine. Never



use parts removed from other machines or from other kits.

This machine has been designed and constructed to provide ten years' service from the fabrication date shown on the rating plate. After this time, whether the machine has been used or not, it should be disposed of according to current legislation in the country in which it is used:

the machine must be disconnected from the power supply, emptied of liquids and cleaned;
the product is classified as WEEE type special waste and is covered by the requisites of the new environmental protection regulations (2002/96/EC WEEE). It must be disposed of separately from ordinary waste in compliance with current legislation and standards.

Special waste. Do not dispose of with ordinary waste.



Alternatively the machine must be returned to the Manufacturer for a complete overhaul.

If you decide to stop using the machine, you are recommended to remove the batteries and dispose of them at an authorised collection centre.

You should also make sure that all parts of the appliance which could represent a hazard, particularly to children, are made safe.

HANDLING AND INSTALLATION

Lifting and transporting the packaged machine

IMPORTANT

During all lifting operations, make sure the packaged machine is firmly anchored to avoid it tipping up or being accidentally dropped.

Always load/unload lorries in adequately lit areas.

The machine, packaged on a wooden pallet by the Manufacturer, must be loaded using suitable equipment (see EC Directive 2006/42 and subsequent amendments and/or additions) onto the transporting vehicle. At destination, it must be unloaded using similar means.

A fork lift truck must always be used to lift the packaged body of the machine. Handle with care to avoid knocking or overturning the machine.

Checks on delivery

When the carrier delivers the machine, make sure the packaging and machine are both whole and undamaged. If the machine is damaged, make sure the carrier is aware of the damage and before accepting the goods, reserve the right (in writing) to request compensation for the damage.

Unpacking

IMPORTANT

When unpacking the machine, the operator must be provided with the necessary personal protection devices (gloves, goggles, etc) to limit the risk of accident.

Unpack the machine as follows:

- ▶ cut and remove the plastic straps using scissors or nippers;
- ▶ open the packaging;
- ▶ remove the bags included in the packaging and check the contents:
 - ▶ guarantee slip;
 - ▶ use and maintenance manual;
 - ▶ battery bridges with terminals (battery model only);
 - ▶ battery charger connector (battery models only);
- ▶ remove the machine from the packaging;
- ▶ clean the outside of the machine in respect of safety regulations;
- ▶ after unpacking the machine, install the batteries (battery models) or connect the electrical connections (cable models). See relevant sections.

The packaging may be kept as it can be reused to protect the machine if it is moved to another site or to a repair workshop.



Otherwise it must be disposed off in compliance with current legislation.

Electrical connections and earth (cable models)

The electrical characteristics of the machine are given on the rating plate. Make sure the frequency and voltage correspond to those of the mains supply where the machine will be operated. As far as voltage is concerned, models where the rating plate specifies a voltage of 230 V can be used with voltages of between 220 V and 240 V. Similarly, models rated at 115 V can be used at between 110 V and 120 V. The frequency on the plate must always correspond to the mains voltage.

IMPORTANT

Make sure the mains circuit is suitably earthed and that the sockets (and any adaptors used) ensure the continuity of the earth conductors.

DANGER

Failure to observe these instructions could cause possibly serious damage to people and things and invalidates the guarantee.

Power supply batteries (battery models)

Two different types of battery may be installed on these machines:

- ▶ tubular leak-proof batteries: the electrolyte level must be checked regularly. When necessary, top up with distilled water until the plates are covered. Do not over fill (5 mm max. above the plates).
- ▶ gel batteries: this type of battery requires no maintenance.

The technical characteristics must correspond to those indicated in the paragraph on the technical specification of the machine. The use of heavier batteries could seriously jeopardise manoeuvrability and lead to the brush motor overheating. Batteries with a lower capacity and weight will require charging more frequently.

They must be kept charged, dry and clean and the connections must be tight.

Batteries: preparation

DANGER

During installation of the batteries or any type of battery maintenance, the operator must be provided with the necessary personal protection devices (gloves, goggles overalls, etc) to limit the risk of accident. Keep away from naked flames, avoid short circuiting the battery poles, avoid sparks and do not smoke.

The batteries are normally supplied filled with acid and ready for use.

If the batteries are dry, before mounting them on the machine, proceed as follows:

- ▶ remove the caps and fill all elements with specific sulphuric acid solution until the plates are entirely covered (this requires at least a couple of passes for each element);
- ▶ leave for 4-5 hours to allow the air bubbles to come to the surface and the plates to absorb the electrolyte;
- ▶ make sure the level of electrolyte is still above the plates and if necessary top up with sulphuric acid solution;
- ▶ close the caps;
- ▶ mount the batteries on the machine (following the procedure described below).

Before starting up the machine for the first time, charge the batteries as follows.

Batteries: installation and connection

DANGER

Check that all switches on the control panel are in the "0" (off) position.

Make sure you connect the terminals marked with a "+" to the positive poles of the battery. Do not check the battery charge by sparking.

Meticulously follow the instructions given below as short circuiting the batteries could cause them to explode.

- ▶ Make sure the dirty water tank is empty and empty if necessary (see relevant paragraph).
- ▶ Remove the dirty water tank (fig. B, ref. 1) off the detergent tank by pulling it upwards, making sure you have previously removed the suction hose and dirty water tank drain hose from their housings.
- ▶ Place the batteries in the battery compartment.

IMPORTANT

Mount the batteries on the machine using lifting means suitable for their weight. The positive and negative poles have different diameters.

- ▶ Connect the battery wiring and bridge terminals to the battery poles.



- ▶ Tighten the terminals on the poles and cover with Vaseline.
- ▶ Put the dirty water tank back on the detergent tank.
- ▶ When using the machine, follow the instructions below.

Batteries: removal

DANGER

When removing the batteries, the operator must be equipped with suitable personal protection devices (gloves, goggles, overalls, safety shoes, etc) to reduce the risk of accidents. Make sure the switches on the control panel are in the "0" position (off) and the machine is turned off. Keep away from naked flames, do not short circuit the battery poles, do not cause sparks and do not smoke. Proceed as follows:

- ▶ disconnect the battery wiring and bridge terminals from the battery poles.
- ▶ if necessary, remove the devices fixing the battery to the base of the machine.
- ▶ lift the batteries from the compartment using suitable lifting equipment.

Battery charger (battery models)

IMPORTANT

Never allow the batteries to become excessively flat as this could damage them irreparably.

INFORMATION

If the machine has an ON-BOARD battery charger (installed by the manufacturer), no operations are required as it will already be ready for use.

Choosing a battery charger (machines without ON-BOARD battery charger)

Make sure the battery charger is compatible with the batteries to be charged:

- ▶ tubular lead batteries: you are recommended to use a 24V - 5A automatic battery charger. However, you should always consult the battery charger manufacturer and manual to confirm the choice.
- ▶ gel batteries: use a charger specific for this type of battery.

Preparing the battery charger

If you wish to use a battery charger not provided with the machine, you must fit it with the connector supplied with the machine (see paragraph "Unpacking" in this manual).

To install the connector, proceed as follows:

- ▶ remove about 13 mm of protective sheath from the red and black wires of the battery charger;
- ▶ insert the wires into the connector contacts and squeeze them forcefully with suitable pliers;
- ▶ respect the polarity (red wire + black wire -) when inserting the wires into the connector.

Lifting and transporting the machine

IMPORTANT

All phases must be performed in an adequately lit room and adopting the safety measures most appropriate to the situation.

The operator must always use personal protection devices.

To load the machine onto a means of transport, proceed as follows:

- ▶ empty the dirty water and detergent tanks;
- ▶ place the machine in the packaging, then rest the packaging on a pallet and fix it with plastic straps;
- ▶ lift the pallet (with the machine) using a fork lift truck and load it onto the means of transport;
- ▶ anchor the machine to the means of transport with cables connected to the pallet and machine itself.

PRACTICAL GUIDE FOR THE OPERATOR

Controls - Description

With reference to fig. C, the machine has the following controls and indicator lights:

- ▶ Power on light (fig. C, ref. 7 - cable model only): green, indicates that the machine's power cable is connected to the mains.
- ▶ Battery charge light (fig. C, ref. 2 - battery models only): 3 LEDs (red, yellow and green) which indicate the level of battery charge. There may be:
 - ▶ red, yellow and green LEDs on: battery voltage >24V;
 - ▶ red and yellow LEDs on: battery voltage <24V;
 - ▶ red LEDs on: battery voltage <23V;
 - ▶ red LED flashing: battery voltage <21.5V, batteries completely flat; after a few seconds the brush



and suction motor shut down;

- ▶ Main switch (fig. C, ref. 3): enables and disables electrical power to all machine functions (to turn the machine off, hold the button down for at least 4 seconds). In the BT version, the LED flashes during operation.
- ▶ Brush button with light (fig. C, ref. 4): enables (LED on) and disables (LED off) the “brush” function. The brush does not start rotating until the brush lever is operated. ECO function (battery models only), used to reduce brush motor power by 20%, to activate this function, operate the “Brush lever” then press the button for a few seconds, until the LED starts flashing.
 - ▶ ECS model, in this version, the light in the button may flash, indicating excessive pressure of the head/microfibre on the work surface.

i INFORMATION

When the brush button is pressed, suction and detergent delivery are also enabled automatically.

- ▶ Suction button with light (fig. C, ref. 5): turns the suction motor on (LED on) and off (LED off) to dry the floor being washed. The light is on when there is power to the suction motor. ECO function (battery models only), used to reduce suction motor power by 20%, to activate this function, operate the “Brush lever” then press the button for a few seconds, until the LED starts flashing. Suction can be activated without operating the brush lever, by holding the button for a few seconds, until the LED starts flashing.
- ▶ Detergent button (fig. C, ref. 6): enables (LED on) and disables (LED off) detergent flow. The detergent does not flow unless the brush is rotating.
- ▶ Brush lever (fig. D, ref. 1): enables brush rotation.
- ▶ Squeegee lever (fig. D, ref. 2): raises (if lowered) or lowers (if raised) the squeegee.
- ▶ Handle regulation lever (fig. D, ref. 3): allows the angle of the handle to be adjusted.
- ▶ Head pressure adjustment knob, ECS model (fig. O, ref. 1): turn the knob clockwise to reduce the pressure of the microfibre on the work surface; turn the knob anticlockwise to increase the pressure of the microfibre on the work surface. To access the knob, remove the dirty water tank from the detergent tank.
- ▶ Speed potentiometer (fig. D, ref. 5, models with electric drive): regulates the machine’s forward or reverse speed.
- ▶ Direction buttons (fig. D, ref. 4, models with electric drive): press these buttons to set movement of the machine to forward or reverse.

Mounting and adjusting the squeegee

The squeegee (fig. A, ref. 5) is responsible for the first phase of drying.

Depending on the type of squeegee mounted on the machine, follow the instructions below to install:

Parabolic squeegee

To mount the squeegee on the machine, proceed as follows:

- ▶ check that the squeegee mount (fig. E, ref. 1) is lowered, otherwise lower it by means of the squeegee lever (fig. D, ref. 2);
- ▶ rotate the machine backwards and rest the handle on the floor;
- ▶ insert the two threaded pins (fig. E, ref. 12) on the squeegee into the slots on the support (fig. E, ref. 1);
- ▶ fix the squeegee by tightening the two knobs (fig. E, ref. 2);
- ▶ insert the sleeve of the suction hose (fig. E, ref. 4) fully into the squeegee;

The squeegee blades scrape the film of water and detergent from the floor and prepare the way for perfect drying. With time, the constant rubbing makes the edge of the blade in contact with the floor rounded and cracked, reducing the drying efficiency and requiring it to be replaced. The state of wear should be checked frequently.

For perfect drying, the squeegee must be adjusted in such a way that the edge of the rear blade bends during operation by about 45° with respect to the floor at every point. Adjust the height of the blade during operation by regulating the height of the wheels positioned behind and alongside the squeegee (fig. E ref. 3).

“V” squeegee

- ▶ check that the squeegee mount (fig. E, ref. 6) is lowered, otherwise lower it by means of the squeegee lever (fig. D, ref. 2);
- ▶ insert the two threaded pins (fig. E, ref. 13) on the squeegee into the slots on the support (fig. E, ref. 6);
- ▶ fix the squeegee by tightening the two knobs (fig. E, ref. 7);
- ▶ insert the sleeve of the suction hose (fig. E, ref. 8) fully into the squeegee;

The squeegee blades scrape the film of water and detergent from the floor and prepare the way for perfect drying. With time, the constant rubbing makes the edge of the blade in contact with the floor rounded and cracked, reducing the drying efficiency and requiring it to be replaced. The state of wear should be checked frequently.

For perfect drying, the squeegee must be adjusted in such a way that the edge of the rear blade bends during operation by about 45° with respect to the floor at every point. Adjust the height of the blade during operation by regulating the height of the wheels positioned on the squeegee (fig. E ref. 9). The slope of the squeegee can also be varied by tightening or loosening the screw (fig. E, ref. 10).



Moving the machine when not in operation.

Roller version

The squeegee blades scrape the film of water and detergent from the floor and prepare the way for perfect drying. With time, the constant rubbing makes the edge of the blade in contact with the floor rounded and cracked, reducing the drying efficiency and requiring it to be replaced. The state of wear should be checked frequently. The machine is fitted with two squeegees, for washing and drying when moving both forwards and backwards. The squeegees feature a pressure adjustment system to adapt them to all types of surface. Pressure is adjusted by turning the knob provided (Fig. E, ref. 14):

- ▶ clockwise increases the pressure.
- ▶ anticlockwise decreases the pressure.

To move the machine, proceed as follows:

- ▶ lift the squeegee using the lever provided (Fig. D, ref. 2) for parabolic squeegee and "V" squeegee;
- ▶ raise the front of the machine off the floor using the handle, then move it to the destination; if the transport wheel is fitted, lift the machine using the handle (standard on the roller version) so that it rests on the wheel.
- ▶ on arrival, lower the front of the machine.

Mounting and changing the brush/drive disks

IMPORTANT

Never work without the brushes and drive disks correctly installed.

Standard version with brushes and drive disks

Brush/drive disk attachment: turn the machine on by pressing the main switch (fig. C, ref. 3) (LED on), then press the brush button (fig. C, ref. 4) (LED on). Rest the brush on the floor in front of the machine. Raise the front of the machine by levering on the handle, then lower it onto the brush, centring it with the brush cover. Operate the brush lever (fig. D, ref. 1) repeatedly until the brush automatically engages on the flange hub. If the manoeuvre is not successful, press on the handle again and repeat the centring and repeated operation of the brush lever.

Brush/drive disk release: turn the machine on by pressing the main switch (fig. C, ref. 3) (LED on), then press the brush button (fig. C, ref. 4) (LED on).

Raise the front of the machine by levering on the handle, then operate the brush lever (fig. D, ref. 1) repeatedly. After a few pulses, the brush (or drive disk) is released and falls to the ground.

Roller version

Attaching the brush roller:

- ▶ switch the machine off, unplug the cable version from the power socket;
- ▶ raise the front of the machine by hand;
- ▶ with the other hand, insert the brush and push it upwards until it is correctly in position (Fig. P, ref. 1);
- ▶ lower the machine

Releasing the brush roller:

- ▶ switch the machine off, unplug the cable version from the power socket;
- ▶ raise the front of the machine by hand;
- ▶ with the other, remove the brush by pulling it downwards (Fig. P, ref. 1);
- ▶ lower the machine.

Detergents - Instructions

IMPORTANT

Always dilute the detergent according to the manufacturer's instructions. Do not use sodium hypochlorite (bleach) or other oxidants, particularly in strong concentrations. Do not use solvents or hydrocarbons. The temperature of the water and detergent must not exceed the maximum indicated in the technical specification. They must be free of sand and/or other impurities.

The machine has been designed for use with low-foam biodegradable detergents made specifically for scrubber driers.

For a complete and up-to-date list of the detergents and chemicals available, contact the Manufacturer.

Use products suitable for the floor and dirt to be removed only.

Follow the safety regulations on use of detergents given in the section "Safety regulations".



Preparing the machine for work

IMPORTANT

Before starting work, wear overalls, ear protectors, non-slip waterproof shoes, mask to protect the respiratory tract, gloves and all other personal protection devices recommended by the supplier of the detergent used or necessitated by the work environment.

Before starting work, proceed as follows:

- ▶ Battery models: check the battery charge (charge if necessary);
- ▶ make sure the dirty water tank (fig. A, ref. 2) is empty. If necessary, empty it;
- ▶ via the opening at the front, fill the detergent tank (fig. A, ref. 8) with a suitable concentration of clean water and low-foam detergent. Leave at least 5 cm between the surface of the liquid and the opening of the tank;
- ▶ mount the most suitable brushes or drive disks for the floor and work to be performed (see paragraph 3.4);
- ▶ make sure that the squeegee (Fig. A, ref. 5) is securely fastened and connected to the suction hose; check that the rear blade is not worn (standard version with brushes and drive disks).
- ▶ adjust the squeegee working height by turning the knob provided (Fig. E, ref. 14), roller version.
- ▶ adjust the brush roller working height by turning the knob provided (Fig. Q, ref. 1), roller version.

i INFORMATION

If you are using the machine for the first time, we recommend trying it on a large obstacle-free surface first to acquire the necessary familiarity.

Always empty the dirty water tank before filling the detergent tank again.

For effective cleaning and to extend the working life of the machine, follow a few simple rules:

- ▶ prepare the work area by removing all possible obstacles;
- ▶ begin working from the furthest point to avoid walking on the area you have just cleaned;
- ▶ choose the straightest possible working routes;
- ▶ divide large floors into parallel rectangular sections.

If necessary, finish off by passing a mop or rag rapidly over parts inaccessible to the scrubber drier.

Working

After setting up the machine, proceed as follows.

- ▶ Connect the machine as follows:
 - ▶ cable model: plug the machine into the mains power socket;
- ▶ lower the squeegee using the lever provided (Fig. D, ref. 2), standard version with brushes and drive disks;
- ▶ press the main switch (fig. C, ref. 3) (LED on);
- ▶ press the brush button (fig. C, ref. 4) "LED on", this will also automatically activate suction and solution flow. To extend machine operating time, the ECO function can be activated (see the paragraph "Controls - Descriptions");
- ▶ select the direction of movement by pressing the button (fig. D, ref. 4) (models with electric drive)
- ▶ adjust the forward/reverse speed by turning the potentiometer (fig D, ref. 5) (models with electric drive)
- ▶ press the brush lever (fig. D, ref. 1);
- ▶ check regularly that detergent is reaching the brushes and top up if necessary;
- ▶ while working, check the quality of washing and adjust the flow of detergent to the brushes using the detergent tap (fig. G, ref. 2), in the ECS model, the detergent tap must always be fully open.

IMPORTANT

Empty the dirty water tank each time you fill the detergent tank.

- ▶ The float switch in the dirty water tank (fig. I, ref. 1) turns suction off when the tank is full. If the switch trips, stop work and empty the tank;
- ▶ Battery models: if the red LED (fig. C, ref. 2) starts flashing, the batteries are nearly flat. After a few seconds, the brush and suction motor shut down to prevent draining the batteries excessively. Charge the batteries.
- ▶ ECS model: during cleaning, make sure the pressure of the microfibre on the work surface remains within the permitted range. If the light in the brush button starts flashing while you are working, reduce the pressure of the microfibre by turning the knob (fig. O, ref. 1). Turn the knob clockwise to reduce the pressure of the microfibre on the work surface; turn the knob anticlockwise to increase the pressure of the microfibre on the work surface. To access the knob, raise the dirty water tank.



At the end of work:

- ▶ release the brush lever (fig. D, ref. 1);
- ▶ turn the machine off by pressing the button (fig. C, ref. 3) for at least 4 seconds.
- ▶ use the lever provided (Fig. D, ref. 2) to raise the squeegee off the floor and prevent continuous pressure from deforming the drying blades, standard version with brushes and drive disks;
- ▶ remove the brush (or drive disk) to prevent it from warping permanently;
- ▶ use the handle to raise the front of the machine and fit the transport wheel, thus preventing continuous pressure from deforming the drying blades and the brush roller, roller version.
- ▶ depending on the model, unplug from the mains socket or disconnect the batteries,
- ▶ empty and clean the dirty water tank.

Some useful tips to get the most from your scrubber drier

In the event of particularly stubborn dirt on the floor, washing and drying can be performed in two separate operations.

Prewashing with brushes or pads

- ▶ press the main switch (fig. C, ref. 3) (LED on);
- ▶ press the brush button (fig. C, ref. 4) (LED on);
- ▶ press the suction button (fig. C, ref. 5) (LED off) to turn suction off;
- ▶ operate the brush lever (fig. D, ref. 1) to enable brush rotation;
- ▶ make sure the suction motor is off and the squeegee is raised;
- ▶ begin washing.
- ▶ adjust the flow of detergent to the brush by means of the detergent tap (fig. G, ref. 2). Flow speed must be regulated according to the operator's chosen advance speed. The slower the machine moves forwards, the less water is needed. Persist when washing particularly dirty points to give the detergent time to perform its chemical action detaching and suspending the dirt and the brushes time to exert an effective mechanical action.

Drying

Lower the squeegee and with the suction motor on, pass over the same area washed previously. The result is equivalent to in-depth washing and subsequent ordinary maintenance will take less time.

To wash and dry at the same time, operate the brush, detergent flow, squeegee and suction motor simultaneously.

Carpet cleaner accessory

This accessory comprises a slider that can wash and dry any type of carpet.

Assembly instructions:

- ▶ switch the machine off.
- ▶ empty the dirty water tank and the clean water tank.
- ▶ tilt the machine by lifting the front, until it is almost vertical.
- ▶ remove the two squeegees (Fig. P, ref. 2-3) by unscrewing the screws.
- ▶ place the slider in position (Fig. P, ref. 2) and fasten it using the screws.
- ▶ lift the cover (Fig. R, ref. 2) and insert the cap supplied together with the accessory, with the holes facing upwards.
- ▶ close the cover to lock it in position.

Operation:

Turn the function selector to CARPET (Fig. R, ref. 1).

Start working, the machine must only be used moving backwards.

Combi accessory

The Combi accessory is used for washing in positions that the floor scrubber cannot reach, such as corners, stairs or around obstacles.

To use the accessory, proceed as follows:

- ▶ switch the machine off.
- ▶ lift the cover (Fig. R, ref. 2) and fit the Combi attachment in position (Fig. S, ref. 1) with the hole facing upwards.
- ▶ close the cover (Fig. R, ref. 2) on the Combi attachment to lock it in position.
- ▶ if installed, turn the function selector to STANDARD (Fig. R, ref. 1).
- ▶ holding the accessory, spray the detergent by activating the lever (Fig. S, ref. 2), and rub the floor with the bristles (Fig. S, ref. 3) to remove the dirt.
- ▶ check at all times that the clean water tank is not empty, as operating the pump without water may cause irreparable damage.
- ▶ turn on the suction and vacuum up the water, sliding the squeegee (Fig. S, ref. 3) across the floor using the part with rubber strips.
- ▶ after having washed the area using the accessory, switch the machine off.



Draining the dirty water

DANGER

Use suitable personal protection devices.

Drain the water with the machine disconnected from the power supply.

The dirty water tank drain hose is at the back of the machine on the right.

To empty the tank:

- ▶ move the machine near a drain;
- ▶ detach the drain hose (fig. A, ref. 7) from its seat by holding it near the fixing spring and pulling horizontally;
- ▶ keeping the end of the hose as high as possible and remove the cap;
- ▶ lower the end of the hose gradually, controlling the intensity of the flow of water by adjusting the height from the ground;
- ▶ check the amount of dirt left in the dirty water tank and if necessary wash it out;
- ▶ close the drain hose with the cap. Check that it is tightly closed and replace the hose in its housing.
- ▶ You are then ready to wash and dry again.

Draining the clean water

DANGER

Use suitable personal protection devices.

Drain the water with the machine disconnected from the power supply.

To empty the tank:

- ▶ move the machine near a drain;
- ▶ unscrew the cap (fig. G, ref. 1);
- ▶ when the detergent tank is completely empty, screw the cap back on (fig. G, ref. 1).

i INFORMATION

The water and detergent solution can also be used to wash the dirty water tank.

PERIODS OF INACTIVITY

If the machine is not used for some time, remove the squeegee and brush (or drive disk), wash them and put them away in a dry place (preferably in a bag or wrapped in plastic film) away from dust.

Make sure the tanks are completely empty and perfectly clean.

Disconnect the machine from the power supply (depending on the model, unplug from the mains or disconnect the connector from the battery wiring).

Battery models: charge the batteries completely before storing them. During long periods of inactivity, you should charge the batteries regularly (at least once every two months) to keep them constantly at maximum charge.

IMPORTANT

If you do not charge the batteries regularly, they may be irrevocably damaged.

BATTERY MAINTENANCE AND CHARGING

DANGER

Do not check the batteries by sparking.

The batteries give off flammable fumes. Put out all fires and hot embers before checking or topping up the batteries.

Perform the operations described above in a ventilated room.

To avoid permanent damage to the batteries, do not run them down completely.

Remember that when the corresponding red light (fig. C, ref. 2) flashes on the control panel, you must charge the batteries.

Charging procedure

- ▶ if the machine does not have an on-board charger, connect the external battery charger connector to the battery wiring connector.
- ▶ if the machine has an on-board battery charger, connect the on-board battery charger power cable (fig. H, ref. 1).

IMPORTANT

In the case of gel batteries, use a charger specific for gel batteries only.



- ▶ Charge the batteries as described in the battery charger manual;
- ▶ at the end of charging, disconnect the connectors;
- ▶ reconnect the battery wiring connector to the machine connector (machine with external battery charger).

MAINTENANCE INSTRUCTIONS

DANGER

Never perform any maintenance operations without first unplugging the machine from the mains (cable version) or disconnecting the batteries.

In cable models, the operator must be able to verify from any position that the machine remains unplugged from the mains socket while maintenance is being carried out.

Maintenance on the electrical circuit and all other operations not explicitly described in this manual must be performed by specialised personnel only, in compliance with current safety legislation and as described in the maintenance manual.

Maintenance - General rules

Performing regular maintenance according to the Manufacturer's instructions improves performance and extends the working life of the machine.

When cleaning the machine, respect the following:

- ▶ avoid the use of high pressure washers. Water could penetrate the electrical compartment or motors leading to damage or the risk of short circuit;
- ▶ do not use steam to avoid the heat warping plastic parts;
- ▶ do not use hydrocarbons or solvents as they could damage the cowling and rubber parts.

Routine maintenance

Float switch and detergent tank filter: cleaning

- ▶ Remove the dirty water tank cap and clean the float switch (fig. I, ref. 1). Make sure it runs freely on the pin.
- ▶ clean the detergent tank filter (fig. N) by unscrewing the cap and extracting the filter assembly.

Squeegee blades: replacing

The squeegee blades collect the film of water and detergent from the floor and prepare the way for perfect drying. With time, the constant rubbing makes the edge of the blade in contact with the floor rounded and cracked, reducing the drying efficiency and requiring it to be replaced.

Turning or replacing the blades:

Parabolic squeegee

- ▶ lower the squeegee by means of the squeegee lever (fig. D, ref. 2);
- ▶ tip the machine backwards and rest the handle on the floor.
- ▶ remove the suction hose sleeve (fig. E, ref. 4) from the squeegee;
- ▶ remove the squeegee (fig. E ref. 1) from its mount by completely unscrewing the two knobs (fig. E ref. 2)
- ▶ remove the blade retainers and blades by unscrewing the knobs (fig. E, ref. 5);
- ▶ reuse the same blade by reversing the edge in contact with the floor until all four edges are worn out, or replace with a new blade, fitting it onto the screws on the body of the squeegee;
- ▶ replace the two blade retainers and the blades and screw up the knobs unscrewed previously;
- ▶ replace the squeegee in its support following the instructions in the section "Mounting and adjusting the squeegee".

"V" squeegee

- ▶ lower the squeegee by means of the squeegee lever (fig. D, ref. 2);
- ▶ remove the suction hose sleeve (fig. E, ref. 8) from the squeegee;
- ▶ remove the squeegee from its mount (fig. E ref. 6) by completely unscrewing the two knobs (fig. E ref. 7)
- ▶ remove the blade pressing devices by opening the catch (Fig. E, ref. 11)
- ▶ reuse the same blade by reversing the edge in contact with the floor until all four edges are worn out, or replace with a new blade, fitting it onto the screws on the body of the squeegee;
- ▶ reposition the two blade pressing devices and the blades, closing the catch.;
- ▶ replace the squeegee in its support following the instructions in the section "Mounting and adjusting the squeegee".

Roller version

- ▶ remove the two squeegees (Fig. P, ref. 2-3) by unscrewing the screws;
- ▶ turn the squeegees over;



- ▶ remove the worn blades by pulling them off, and then replace them with new ones, inserting the protruding tooth into the socket;
- ▶ replace the squeegee on the its support.

Fuses: replacement (battery models) (Fig. L)

The fuse protecting the electrical circuit is located on the battery bridge.

To replace it:

- ▶ make sure the dirty water tank is empty and empty if necessary;
- ▶ remove the dirty water tank to access the batteries;
- ▶ lift the fuse holder lid (fig. L) and remove the fuse;
- ▶ fit a new fuse and close the fuse holder cover.
- ▶ lower the dirty water tank.

Fuse table: for the complete fuse table, see the spare parts catalogue.

Fuses: replacement (cable models) (fig. M)

The fuses protecting the electrical components are on the electrical components box.

To replace:

- ▶ make sure the dirty water tank is empty and empty if necessary;
- ▶ remove the dirty water tank to access the electrical components compartment;
- ▶ open the cover of the fuse holder on the electrical components box and remove the fuse;
- ▶ fit a new fuse and close the fuse holder cover.
- ▶ lower the dirty water tank.

Fuse table: for the complete fuse table, see the spare parts catalogue.

IMPORTANT

Never use a fuse with a higher amperage than specified.

If a fuse continues to blow, the fault in the wiring, boards (if present) or motors must be identified and repaired. Have the machine checked by qualified personnel.

Routine maintenance

Daily operations

After each day's work, proceed as follows:

- ▶ disconnect the machine from the power supply;
- ▶ empty the dirty water tank and clean if necessary;
- ▶ clean the squeegee blades and check for wear. If necessary, replace.
- ▶ check that the suction hole in the squeegee is not blocked, if necessary remove encrusted dirt;
- ▶ Battery model: charge the batteries according to the procedure described;

Weekly operations

- ▶ clean the dirty water tank float switch and make sure it is working correctly;
- ▶ clean the suction hose;
- ▶ clean the dirty water tank and detergent tank;
- ▶ Battery model: check the level of battery electrolyte and top up with distilled water if necessary;

Six monthly operations

Have the electrical circuit checked by qualified personnel.

TROUBLESHOOTING

How to resolve possible problems

[B]= battery machines

[C]= cable machines

Possible problems affecting the whole machine.

PROBLEM	CAUSE	REMEDY
The machine does not function	[B]= battery connector disconnected	[B]= connect the batteries to the machine
	[B]= the batteries are flat	[B]= charge the batteries.
	[B] [C]= fuse blown	[B] [C]= replace the fuse
	[B]= temperature power board > 85°C	[B]= stop the machine, leave to cool down for 45'
	[B]= MOSFET temperature > 150°C	[B]= stop the machine, leave to cool down for 45'
	[C]= the machine is not plugged into the mains socket	[C]= plug into the mains socket
The brush doesn't rotate	the brush button LED is off	press the brush button
	the LED in the brush button is flashing	reduce the pressure of the microfibre on the work surface
	the brush lever has not been pressed	press the brush lever
	[B] [C] the brush motor thermal cutout has tripped; the motor has overheated	[B] [C] release the brush lever, press the brush button (LED off), leave the machine to cool down for at least 45'
	[B]= MOSFET temperature > 150°C	[B]= stop the machine, leave to cool down for 45'
	[B]= excessive motor absorption >30 A for 1 second	[B]= stop the machine and check the motor
	the power supply or motor thermal cutout connectors are disconnected	reconnect the power supply or motor thermal cutout connectors
	[C]= fuse blown	[B] [C]= replace fuse
	[B]= the batteries are flat	[B]= charge the batteries
	the reduction unit is faulty	have the reduction unit replaced
the motor is faulty	have the motor replaced	
The brush motor has trouble in starting (cable models only)	you are working with a dry brush on a very rough floor	open the detergent tap
	you are working with power cable extensions with an inadequate section, or the voltage is considerably lower than the rated value for the scrubber drier as shown on the rating plate (15% less)	avoid the use of inappropriate extensions. Increase the section of the electric wires and locate sockets with a higher voltage
	the motor is faulty	have the motor replaced
The machine does not clean evenly	the brush or disk is worn	replace
No detergent is delivered	the detergent button LED is off	press the detergent button
	detergent tank empty	fill the detergent tank
	• the brush motor is off	turn the motor on by operating the brush lever
	the hose delivering the detergent to the brush is blocked	unblock and open the circuit
	the tap is dirty or faulty	have the tap cleaned or replaced
	the solenoid valve is faulty	replace the solenoid valve
the filter is dirty	clean the filter	
The detergent flow does not stop	the solenoid valve is faulty	replace the solenoid valve



The suction motor does not start	the suction button LED is off	press the suction button.
	There is no power to the suction motor or the motor is faulty	check that the motor power connector is correctly connected to the main wiring; if it is correctly connected, have the motor replaced
	[B]= MOSFET temperature > 150°C	[B]= stop the machine, leave to cool down for 45'
	[B]= excessive motor absorption >30 A for 2 second	[B]= stop the machine and check the motor

The squeegee does not clean or suction is ineffective	the edge of the rubber blades in contact with the floor is worn	replace the rubber blade
	the squeegee or hose is blocked or damaged	unblock and repair the damage
	the float switch has tripped (dirty water tank), is clogged by dirt or broken	empty the dirty water tank or reset the float switch
	the suction hose is blocked	unblock the hose
	the suction hose is not connected to the squeegee or is damaged	connect or repair the hose
	there is no power to the suction motor or the motor is faulty	see: "The suction motor does not start"

The batteries do not provide the normal work time (battery models only)	the battery poles and charging terminals are dirty and oxidised	clean and grease the poles and terminals, charge the batteries
	the electrolyte level is low	top up all the elements with distilled water as described in the instructions
	the battery charger does not work or is unusable	see battery charger instructions
	there are considerable differences in density between the various elements of the battery	replace the damaged battery

The battery discharges too fast during use, even though it has been charged correctly and when tested with a hydrometer at the end of recharging, it turned out to be uniformly charged (battery models only)	the battery is new and does not deliver 100% of its expected capacity	the battery must be "run-in" by performing 20-30 charges and discharges to obtain maximum performance
	the machine is being used at maximum capacity for continuous periods and the working time is not sufficient	if possible, use batteries with a higher capacity or replace the batteries with others charged previously
	the electrolyte has evaporated and does not cover the plates completely	top up all elements with distilled water until the plates are covered then charge the battery

The battery discharges too fast during use, recharging with an electronic battery charger is too fast and after recharging the battery supplies the right voltage (about 2.14V for each element without load), but when tested with a hydrometer is found not to be uniformly charged (battery models only)	the battery supplied filled with acid by the Manufacturer has been stored for too long before being charged and used for the first time	if recharging with a normal battery charger is not effective, you must use a double recharging cycle: - charge it slowly over a 10 hour period at a current of 1/10 the nominal capacity for 5 hours (e.g. for a 100Ah(5) battery the current must be set at 10A, using a manual battery charger); - rest for one hour; - charge it with the normal battery charger.
---	---	---

At the end of charging with the electronic battery charger, the battery does not provide the correct voltage (about 2.14 V per element without load) and appears to be uniformly not charged when tested with a hydrometer (battery models only)	The battery has not been connected to the battery charger (for example, because the low voltage connector of the battery charger has been erroneously connected to the machine connector)	connect the battery charger to the battery connector
	the battery charger and power socket to which the battery is connected are not compatible	check that the power supply characteristics indicated on the battery charger rating plate comply with those of the mains power supply
	the battery charger has not been installed correctly	taking the actual voltage available at the socket into account, make sure that the connections of the primary of the transformer inside the battery charger are correct (consult the battery charger manual)
	the battery charger is not working	make sure there is voltage to the battery charger, that the fuses are not blown and that the current reaches the battery; try charging with another rectifier. If the battery charger is not working, contact the technical service centre and indicate the serial number of the battery charger



At the end of charging with the electronic battery charger, the battery does not provide the correct voltage (about 2.14 V per element without load) and only one or a few elements are found to be discharged when tested with a hydrometer (battery models only)	one or more elements are damaged	replace the damaged elements if possible. For 6 or 12 V single block batteries, replace the entire battery
--	----------------------------------	---

The electrolyte in the battery is turbid (battery models only)	the battery has reached the end of the charging/ discharging cycles declared by the manufacturer	replace the battery
	the battery has been charged with too high a current	replace the battery
	the battery has been charged beyond the limit suggested by the Manufacturer	replace the battery











**IPC**

IP CLEANING S.p.A.
Sede Legale - Registered Office
Viale Treviso n° 63 - fraz. Summaga
30026 Portogruaro (VE) ITALY



IT	DICHIARAZIONE DI CONFORMITA' "CE" Dichiariamo sotto la nostra esclusiva responsabilità che il prodotto al quale questa dichiarazione si riferisce è conforme alle seguenti Direttive Comunitarie:	FI	YHDENMUKAISUUSVAKUUTUS "CE" Vakuutamme omalla vastuullamme, että seuraava tuote jota tämä vakuutus koskee, on yhdenmukainen seuraavassa Euroopan yhteisön direktiivillä:
EN	"CE" CONFORMITY DECLARATION We declare on our own responsibility that the product to which this declaration refers is in accordance with the following European Community Directives:	EL	Δηλώνουμε φέροντας την αποκλειστική ευθύνη ότι το προϊόν στο οποίο αναφέρεται η δήλωση αυτή είναι σύμφωνα με τις ακόλουθες οδηγίες της Ευρωπαϊκής Κοινότητας:
FR	DECLARATION DE CONFORMITE "CE" Nous déclarons sous notre exclusive responsabilité que le produit auquel cette déclaration se réfère est conforme aux directives européennes suivantes communautaires:	SK	PREHLÁSENIE "EU" O ZHODNOSTI Prehlasujeme na vlastnú zodpovednosť, že výrobok, na ktorý sa vzťahuje toto prehlásenie je zhodný s nasledujúcimi Európskeho spoločenstva:
DE	"CE" KONFORMITÄTSEKLRÄRUNG Auf unserer Alleinverantwortung erklären wir, daß das Produkt, auf das sich diese Erklärung bezieht entspricht den folgenden Richtlinien der Europäischen Gemeinschaft:	HU	"CE" MEGFELELŐSÉGI NYILATKOZAT Saját felelősségünk alatt kijelentjük, hogy a termék, amelyre a nyilatkozat vonatkozik, megfelel az következő európai közösségi irányelvek:
ES	DECLARACIÓN "CE" DE CONFORMIDAD Bajo nuestra exclusiva responsabilidad, declaramos que el producto, al que esta declaración se refiere, es conforme con las siguientes directivas comunitarias:	CS	PROHLÁŠENÍ "CE" O SHODĚ Prohlasujeme vylučně na vlastní zodpovědnost, že výrobek, na který se vztahuje toto prohlášení je ve shodě s následujícími Evropského společenství:
PT	DECLARAÇÃO "CE" DE CONFORMIDADE Declaramos sob a nossa exclusiva responsabilidade que o produto ao qual esta declaração se refere está em conformidade com as seguintes directivas comunitárias:	ET	"CE" VASTAVUSDEKLARATSIOON Deklareerime meie ainuvastutuse juures, et see toode vastab järgmistele standarditele ja Euroopa Ühenduse direktiivide:
NL	DECLARAÇÃO "CE" DE CONFORMIDADE Declaramos sob a nossa exclusiva responsabilidade que o produto ao qual esta declaração se refere está em conformidade com as seguintes directivas comunitárias:	LT	"CE" ATITIKTIES DEKLARACIJA Prisiimdami visą atsakomybę, mes pareiškiame, kad produktas, kuriam taikoma ši deklaracija, atitinka šiuos Europos Bendrijos direktyvas:
DA	ÖVERENSSTEMMELSEERKLÄRING "CE" Vi försäkrar under eget ansvar att följande produkt som omfattas af denna erklaring er i överensstämmelse med villkorene i följande EU direktiver:	SL	IZJAVA O SKLADNOSTI "CE" Izjavljamo na našo odgovornost, da je izdelek, na katerega se nanaša ta deklaracija, v skladu s sledečimi direktivami Evropske skupnosti:
SV	FÖRSÄKRAN OM ÖVERENSSTÄMMELSE "CE" Vi försäkrar under eget ansvar att följande produkt som omfattas av denna bekräftelsen är i överensstämmelse med villkoren i följande Europeiska gemenskapens direktiv:	PL	DEKLARACJA ZGODNOŚCI "UE" Oświadczamy na naszą wyłączną odpowiedzialność, że produkt, którego dotyczy niniejsza karta gwarancyjna, jest zgodny z następującymi dyrektywami Wspólnoty Europejskiej:
N	BEKREFTELSE OM ÖVERENSSTEMMELSE "CE" Vi försäkrar under eget ansvar att följande produkt som omfattas av denna bekräftelsen är i överensstämmelse med villkoren i följande disse EU-direktivene:	LV	"CE" ATITIKTIES DEKLARACIJA Prisiimdami visą atsakomybę, mes pareiškiame, kad produktas, kuriam taikoma ši deklaracija, atitinka šiuos Europos Kopienas direktyvas:

2006/42/CE - 2004/108/CE - 2000/14/CE - 2011/65/EU

Norme armonizzate applicate - Applied harmonised standards: Altri standards applicati - Others applied standards:

Prodotto-Product:

LAVASCIUGAPAVIMENTI - AUTOMATIC SCRUBBER
Modello-Model-Modèle-Modell-Modelo-Modell-Malli-Montelo-
Mudel-Modelis:

Matricola-Serial n.-Maticule-Maschinennummer-Matricula-Serie-
nummer-Sarjanumero-Registrierungsnummer - (Ariqmos) Mhtwron-
Výrobné číslo-Sorozatszám-Výrobní číslo-Seeria nr-Serijos
Nr.-Serijška številka-Nr serijny-Serijos Nr.:

--	--

Persona autorizzata a costituire il Fascicolo Tecnico.
Person authorised to compile the Technical File.

POSITION: **General Manager** Date: 27/08/15

NAME: **Federico De Angelis** Signature:

IP CLEANING S.p.A.
Viale Treviso n° 63 - fraz. Summaga
30026 Portogruaro (VE) ITALY

Testato - Checked - Essayé - Geprüft - Testado - Provékort - Koeajettu - Getest -
Leverans - Dokimasmeno - Vyskušano - Bevizsgált - Testovano - Kontrolltud - Patikrinta
- Preizkušeno - Sprawdzono - Patikrinta

Serial n°

Incollare la matricola sulla garanzia.
Coller la matricule sur la carte garantie.
Pegar la matricula en la garantía.
Registrierungsnummer op die garantie plakken.
Klistri serienummeret på garantiseddelen.
Liimaa sarjanumero takuutodistukseen.
Stik the serial number on the warranty card.
Maschinennummer auf den Garantieschein kleben.
Cole o número de matricula na garantia.

Klistri serienummeret på garantiseddelen.
Koll/ste ton ariqmÖ mhtréon sthsh eggÜhs
Výrobné číslo nalepte na záručný list.
A sorozatszámot ragassza a garancialevélre.
Nalepiť výrobní číslo na záruku.
Seerianumber tuleb kinnitada garantikaardile.
Garantiiname pase turi būti nurodytas serijos
numeris.
Serijška številka mora biti nalepljena na garanciji.
Należy nakleić numer serijny na kartę
gwarancyjną.

Il collaudatore:

--

Serial n°



IPC

IP CLEANING S.p.A.
Sede Legale - Registered Office
Viale Treviso n° 63 - fraz. Summaga
30026 Portogruaro (VE) ITALY



IT	DICHIARAZIONE DI CONFORMITÀ "CE" Dichiariamo sotto la nostra esclusiva responsabilità che il prodotto al quale questa dichiarazione si riferisce è conforme alle seguenti Direttive Comunitarie:	FI	YHDENMUKAISUUSVAKUUTUS "CE" Vakuutamme omalla vastuullamme, että seuraava tuote jota tämä vakuutus koskee, on yhdenmukainen seuraavassa Euroopan yhteisön direktiivillä:
EN	"CE" CONFORMITY DECLARATION We declare on our own responsibility that the product to which this declaration refers is in accordance with the following European Community Directives:	EL	Δηλώνουμε φέροντας την αποκλειστική ευθύνη ότι το προϊόν στο οποίο αναφέρεται η δήλωση αυτή είναι σύμφωνα με τις ακόλουθες οδηγίες της Ευρωπαϊκής Κοινότητας:
FR	DECLARATION DE CONFORMITE "CE" Nous déclarons sous notre exclusive responsabilité que le produit auquel cette déclaration se réfère est conforme aux directives européennes suivantes communautaires:	SK	PREHLÁSENIE "EU" O ZHODNOSTI Prelhasujeme na vlastnú zodpovednosť, že výrobok, na ktorý sa vzťahuje toto prehlásenie je zhodný s nasledujúcimi Európskeho spoločenstva:
DE	"CE" KONFORMITÄTSEKLRÄRUNG Auf unserer Alleinverantwortung erklären wir, daß das Produkt, auf das sich diese Erklärung bezieht entspricht den folgenden Richtlinien der Europäischen Gemeinschaft:	HU	"CE" MEGFELELŐSÉGI NYILATKOZAT Saját felelősségünk alatt kijelentjük, hogy a termék, amelyre a nyilatkozat vonatkozik, megfelel az következő európai közösségi irányelvek:
ES	DECLARACIÓN "CE" DE CONFORMIDAD Bajo nuestra exclusiva responsabilidad, declaramos que el producto, al que esta declaración se refiere, es conforme con las siguientes directivas comunitarias:	CS	PROHLÁŠENÍ "CE" O SHODĚ Prohlašujeme vylučně na vlastní zodpovědnost, že výrobek, na který se vztahuje toto prohlášení je ve shodě s následujícími Evropského společenství:
PT	DECLARAÇÃO "CE" DE CONFORMIDADE Declaramos sob a nossa exclusiva responsabilidade que o produto ao qual esta declaração se refere está em conformidade com as seguintes directivas comunitárias:	ET	"CE" VASTAVUSDEKLARATSIOON Deklareerime meie ainuvastutuse juures, et see toode vastab järgmistele standarditele ja Euroopa Ühenduse direktiivide:
NL	DECLARAÇÃO "CE" DE CONFORMIDADE Declaramos sob a nossa exclusiva responsabilidade que o produto ao qual esta declaração se refere está em conformidade com as seguintes directivas comunitárias:	LT	"CE" ATITIKTIES DEKLARACIJA Prisiimdami visą atsakomybę, mes pareiškiame, kad produktas, kuriam taikoma ši deklaracija, atitinka šiuos Europos Bendrijos direktyvas:
DA	ÖVERENSSTEMMELSEERKLÄRING "CE" Vi försäkrar under eget ansvar att följande produkt som omfattas af denna erklaring er i överensstämmelse med villkorene i följande EU direktiver:	SL	IZJAVA O SKLADNOSTI "CE" Izjavljamo na našo odgovornost, da je izdelek, na katerega se nanaša ta deklaracija, v skladu s sledečimi direktivami Evropske skupnosti:
SV	FÖRSÄKRAN OM ÖVERENSSTÄMMELSE "CE" Vi försäkrar under eget ansvar att följande produkt som omfattas av denna bekräftelsen är i överensstämmelse med villkoren i följande Europeiska gemenskapens direktiv:	PL	DEKLARACJA ZGODNOŚCI "UE" Oświadczamy na naszą wyłączną odpowiedzialność, że produkt, którego dotyczy niniejsza karta gwarancyjna, jest zgodny z następującymi dyrektywami Wspólnoty Europejskiej:
N	BEKREFTELSE OM ÖVERENSSTEMMELSE "CE" Vi försäkrar under eget ansvar att följande produkt som omfattas av denna bekräftelsen är i överensstämmelse med villkoren i följande disse EU-direktivene:	LV	"CE" ATITIKTIES DEKLARACIJA Prisiimdami visą atsakomybę, mes pareiškiame, kad produktas, kuriam taikoma ši deklaracija, atitinka šiuos Europos Kopienas direktyvas:

2006/42/CE - 2004/108/CE - 2006/95/CE - 2000/14/CE - 2011/65/CE

Norme armonizzate applicate - Applied harmonised standards: Altri standards applicati - Others applied standards:

Prodotto-Product:
LAVASCIUGAPAVIMENTI - AUTOMATIC SCRUBBER
Modello-Model-Modèle-Modell-Modelo-Modell-Malli-Montelo-Mudel-Modelis:

Matricola-Serial n.-Maticule-Maschinennummer-Matricula-Seriennummer-Sarjanumero-Registriationsnummer -(Ariqmos) Mhtwron-Výrobné číslo-Sorozatszám-Výrobní číslo-Seeria nr-Serijos Nr.-Serijska številka-Nr serijny-Serijos Nr.:

Persona autorizzata a costituire il Fascicolo Tecnico.
Person authorised to compile the Technical File.

POSITION: **General Manager** Date: 27/08/15

NAME: **Federico De Angelis** Signature:

IP CLEANING S.p.A.
Viale Treviso n° 63 - fraz. Summaga
30026 Portogruaro (VE) ITALY

Testato - Checked - Essayé - Geprüft - Testado - Provékort - Koeajettu - Getest -
Leverans - Dokimasmeno - Vyskušano - Bevizsgált - Testovano - Kontrolltud - Patikrinta
- Preizkušeno - Sprawdzono - Patikrinta

Serial n°

Incollare la matricola sulla garanzia.
Coller la matricule sur la carte garantie.
Pegar la matricula en la garantía.
Registriesnummer op de garantie plakken.
Klistri serienummeret på garantiseddelen.
Liimaa sarjanumero takuutodistukseen.
Stik the serial number on the warranty card.
Maschinennummer auf den Garantieschein kleben.
Cole o número de matricula na garantia.

Klistri serienummeret på garantiseddelen.
Koll/ste ton ariqmÖ mhtréon sthsh eggÜhs
Výrobné číslo nalepte na záručný list.
A sorozatszámot ragassza a garancialevélre.
Nalepiti výrobní číslo na záruku.
Seerianumber tuleb kinnitada garantikaardile.
Garantiiname pase turi būti nurodytas serijos numeris.
Serijska številka mora biti nalepljena na garanciji.
Należy nakleić numer serijny na kartę gwarancyjną.

Il collaudatore:



Serial n°

Integrated Professional Cleaning



IPC Gansow

Sede legale - Registered Office
V.le Treviso, 63
30026 Summaga di Portogruaro (Venice) Italy
Tel. +39 0421 205511 - Fax +39 0421 204227
Internet address: <http://www.ipcleaning.com>
Email address: [http: info@ipcleaning.com](mailto:info@ipcleaning.com)

Sede produttiva - Production premises
Via Cartesio, 39
42100 Villa Bagno (R.E) Italy
Tel. +39 0522 266000 - Fax +39 0522 342045
Internet address: <http://www.ipcgansow.com>



PLDC01929_15

